

## Photos of the Units

<b>Ball Screw Drive, Ball Guide</b> 1  2  3 	<b>Belt Drive, Ball Guide</b> 6  7  8  9 	<b>Linear Lifting Units</b> 14  15  16 
<b>Ball Screw Drive, Slide Guide</b> 4  5 	<b>Belt Drive, Slide Guide</b> 10  11 	<b>Linear Rod Units</b> 17  18  19 
	<b>Belt Drive, Wheel Guide</b> 12  13 	

## Definition of Forces

Please use these definitions when referring to a force that are applied to the unit.

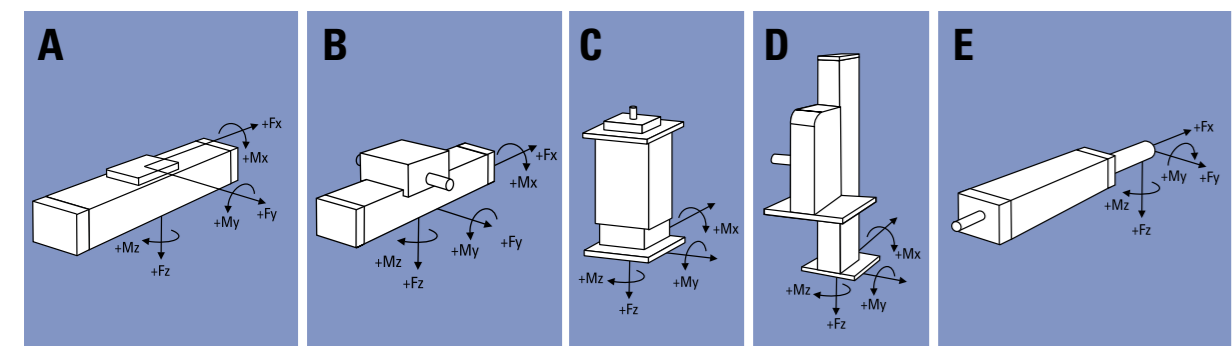

### EUROPE

**United Kingdom**  
 Danaher Motion  
 Chartmoor Road, Chartwell Business Park  
 Leighton Buzzard, Bedfordshire  
 LU7 4WG, United Kingdom  
 Phone: +44 (0)1525 243 243  
 Fax: +44 (0)1525 243 244  
 E-mail: sales.uk@danahermotion.com

**Germany**  
 Danaher Motion GmbH  
 Sales Office North  
 Wacholderstr. 40-42  
 40489 Düsseldorf  
 Germany  
 Phone: +49 (0) 203 9979 214  
 Fax: +49 (0) 203 9979 3214  
 E-Mail: iris.tolusch@danahermotion.com

Danaher Motion GmbH  
 Sales Office South West  
 Brückenfeldstraße 26/1  
 75015 Bretten  
 Germany  
 Phone: +49 (0) 7252 97390 56  
 Fax: +49 (0) 7252 97390 55  
 E-Mail: kerstin.mueller@danahermotion.com

Danaher Motion GmbH  
 Sales Office South East  
 Kiesgräble 7  
 89129 Langenau  
 Germany  
 Phone: +49 (0) 7471 62 23 23  
 Fax: +49 (0) 7471 62 23 26  
 E-Mail: ursula.koschak@danahermotion.com

**France**  
 Danaher Motion  
 C.P 80018  
 12, Rue Antoine Becquerel – Z.I. Sud  
 F-72026 Le Mans Cedex 2  
 France  
 Phone: +33 (0) 243 50 03 30  
 Fax: +33 (0) 243 50 03 39  
 E-mail: sales.france@tollo.com

**Italy**  
 Danaher Motion srl  
 Largo Brughetti  
 I-20030 Bovisio Masciago  
 Italy  
 Phone: +39 0362 594260  
 Fax: +39 0362 594263  
 E-mail: info@danahermotion.it

### Sweden

Danaher Motion  
 Box 9053  
 SE-291 09 Kristianstad  
 Sweden  
 Phone: +46 (0) 44-24 67 00  
 Fax: +46 (0) 44-24 40 85  
 E-mail: sales.scandinavia@danahermotion.com

**Switzerland**  
 Danaher Motion SA  
 La Pierreire 2  
 1029 Villars-Ste-Croix  
 Switzerland  
 Phone: +41 (0) 21 631 33 33  
 Fax: +41 (0) 21 636 05 09  
 E-mail: info@danaher-motion.ch

### USA, CANADA and MEXICO

Danaher Motion  
 203A West Rock Road  
 Radford, VA 24141 USA  
 Phone: 1-540-633-3400  
 Fax: 1-540-639-4162  
 E-mail: DMAC@danahermotion.com  
 Literature: LitRequest@danahermotion.com

### ASIA

**China**  
 Danaher Motion  
 Rm 2205, Scitech Tower  
 22 Jianguomen Wai Street  
 Beijing, China, 100004  
 Phone: +86 10 6515 0260  
 Fax: +86 10 6515 0263  
 E-mail: chinainfo@danahermotion.com.cn

**Japan**  
 Danaher Motion Japan  
 2F, Tokyu Reit Hatchobori Bldg  
 2-7-1 Hatchobori Chuo-ku,  
 Tokyo 104-0032 Japan  
 Phone: +81-3-6222-1051  
 Fax: +81-3-6222-1055  
 E-mail: info@danahermotion.co.jp

DW110612GB-0777  
 Information & specifications subject to change at any time. Printed in Sweden.  
 © Danaher Motion GmbH 2007

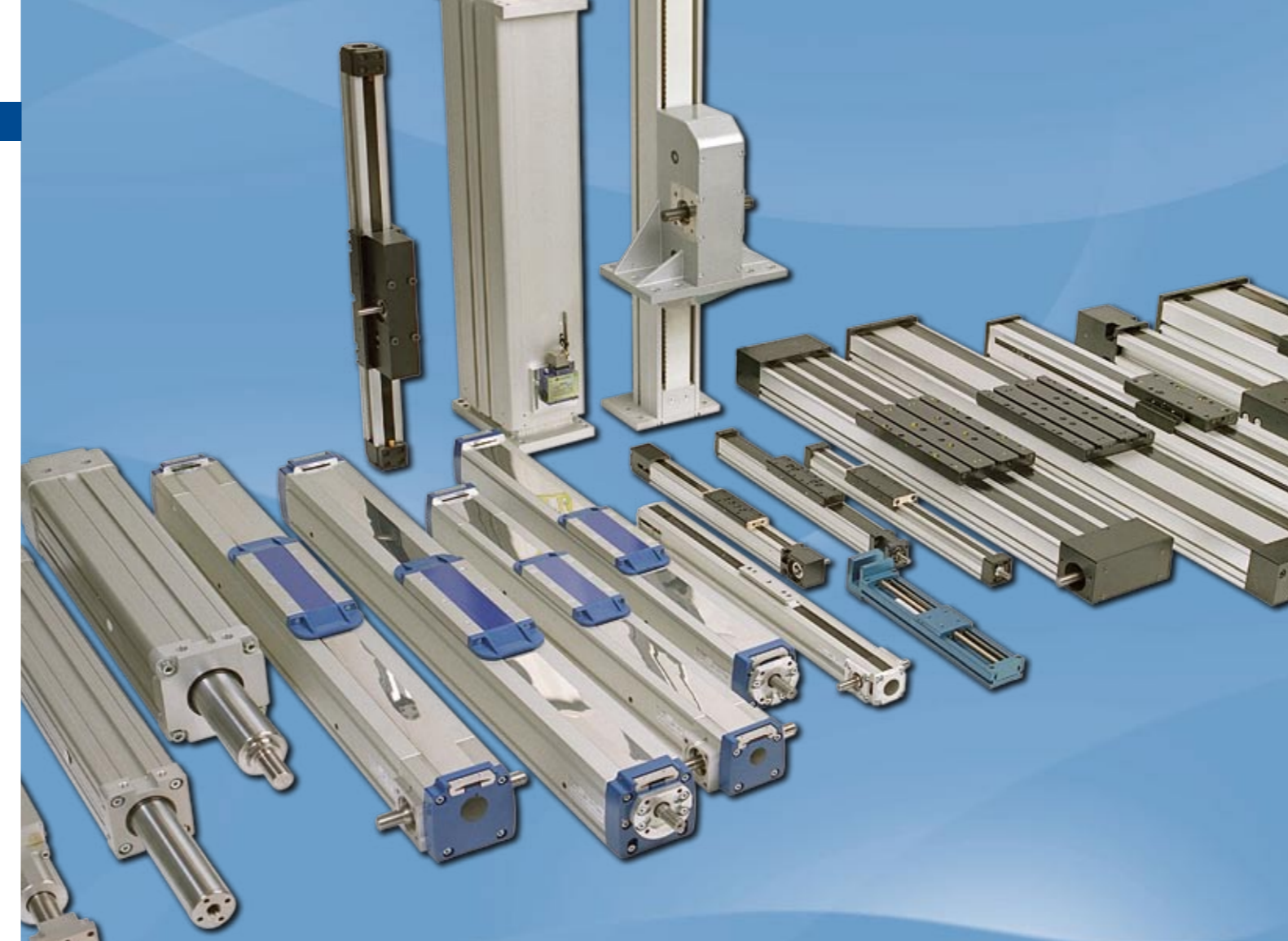

# Linear Units Quick Selection Guide



## Product Groups

Danaher Motions linear units are divided in to seven product groups depending of the drive and guiding method being used.

### Ball screw driven - ball guided units

Units designed for high thrust, payload, precision and stiffness.

- Force up to 12000 N
- Repeatability down to 0,005mm

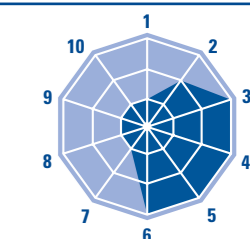

### Ball screw driven - slide guided units

Low cost units for high thrust applications and demanding environments.

- Durable guide system
- Washdown protected version

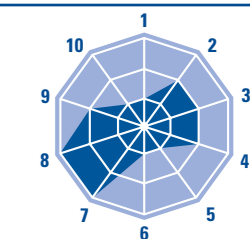

### Belt driven - ball guided units

Smooth running units for high speed, acceleration and load requiring a long lifetime.

- Speed up to 5 m/s
- Acceleration up to 40 m/s²

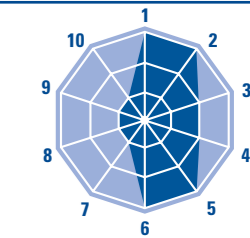

### Belt driven - slide guided units

Units for applications requiring smooth travel, high speed, high acceleration and low maintenance.

- Cost efficient guide system
- Chemically protected versions

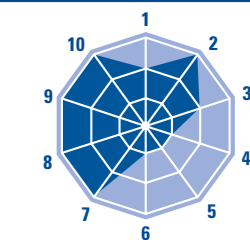

### Belt driven - wheel guided units

Units for high speed, high acceleration, smooth motion and medium to high loads.

- Speed up to 10 m/s
- Acceleration up to 40 m/s²

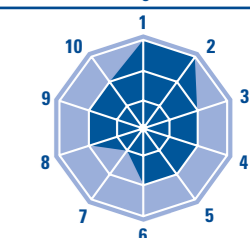

### Linear lifting units

Units for lifting applications that often are used in X-Y configurations in combination with other linear units.

1. Velocity
2. Acceleration
3. Repeatability
4. Force
5. Load torque
6. Stiffness
7. Guide robustness
8. Cost
9. Maintenance
10. Noise

### Linear rod units

Units designed for lifting applications or for the replacement of hydraulic and pneumatic cylinders.

